

**HOFMANN®** 

# *duolift*® **SERIES**



**2-POST LIFTS**

**ENGINEERING UNLEASHED™**

duolift® HL3500

## HYDRAULIC LIFT

THE CAR DEALERSHIP LIFT FOR PASSENGER CARS, SUV AND TRANSPORTERS WITH STANDARD AND HIGH ROOFS (I.E. VW T5 LONG)



### 3 STAGE ARMS WITH VERSYMMETRIC® TECHNOLOGY

Front and rear 3 stage arms always allow a perfect access to the pick up points of the vehicle.



### CONTROLS

Positioned in an ergonomic place on the primary column with clear indications of each push button.

## VERSYMMETRIC® TECHNOLOGY

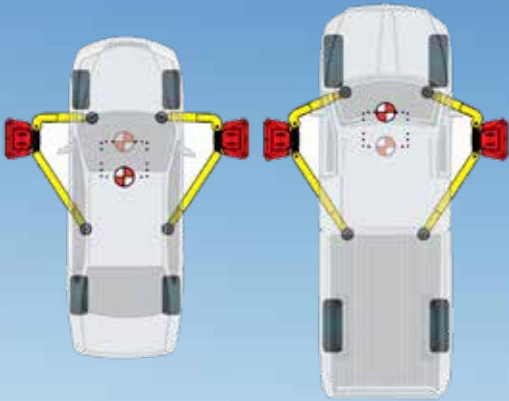

Combines the advantages of an asymmetric and a symmetric lift and improves the ergonomics when placing the arms to lift the car.

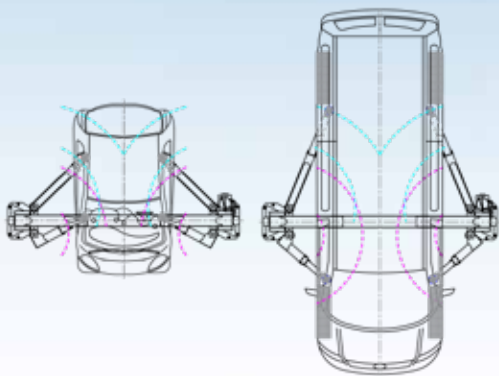

Thanks to the Versymmetric® Technology vehicles with short (i.e. Smart) as well as Transporters (HL 3500) and long wheel base (i.e. mid size vans - HL 4500) can be lifted comfortably.



HOFMANN®

## CE STOP

Instead of mechanical foot protectors to ensure optimum safety.

## POWER PACK

Mounted high thus offering reduced noise performance.

## SHUT-OFF BAR

Prevents cars from being damaged should they touch the upper part of the lift.

duolift® HL4500

HYDRAULIC LIFT



## COMFORT LOWERING

The lift will automatically go up a little bit to release the carriage from the safety lock and will then automatically lower the vehicle.

**THE INDEPENDENT WORKSHOP LIFT FOR VEHICLES FROM THE SMALLEST SIZE (I.E. SMART) UP TO MEDIUM SIZE VANS**



## SAFETY LOCK

The lock is active during the complete lifting process, by simply pressing the lock button the carriage can be set into the lock whenever wanted / required.

## FLEXIBLE INSTALLATION

The lift is available in 2 versions that can be installed in 2 different heights (low and high). Check comparison table. (HL 4500)



## OPTIONAL

Secondary control box



duolift® HL5500

## HYDRAULIC LIFT

### THE VAN LIFT FOR MEDIUM TO HEAVY-DUTY VEHICLES (I.E. LONG VAN VERSIONS)



#### 3 STAGE ARMS (SYMMETRIC)

Front and rear 3 stage arms always allow a perfect access to the pick up points of the vehicle.



#### CONTROLS

Positioned in an ergonomic place on the primary column with clear indications of each push button.



#### CARRIAGE

Enhances stability, providing a solid foundation for any lifting operation with arm lock system that ensures superior safety and reliability.



#### SAFETY LOCK

The lock is active during the complete lifting process, by simply pressing the lock button the carriage can be set into the lock whenever wanted / required.

#### SHUT-OFF BAR

Prevents cars from being damaged should they touch the upper part of the lift.



#### COMFORT LOWERING

The lift will automatically go up a little bit to release the carriage from the safety lock and will then automatically lower the vehicle.



#### OPTIONAL

Secondary control box



duolift® MTF3000

## ELECTRO-MECHANICAL LIFT

THE STANDARD FOR  
ALL WORKSHOPS



Special arms and pads configuration to fit a wide range of vehicles without using additional accessories



### AUTOMATIC LUBRICATION SYSTEM

Lifting nuts made of wear-proof material (Nylatron®) and automatic lubrication of lifting screws and safety nuts.



### CARRIAGE AND ARMS

Easy accommodation of low-bed cars due to 98 mm minimum pick-up height.



### AUTOMATIC LOCKING OF ARMS



See datasheet for more details

TECHNICAL SPECIFICATIONS	HYDRAULIC LIFT		HYDRAULIC LIFT		HYDRAULIC LIFT	ELECTRO-MECHANICAL LIFT
	HL 3500		HL 4500		HL 5500	MTF 3000
Version	Standard	Tall	Standard	Tall		
Lifting capacity	3.500 kg		4.500 kg		5.500 kg	3.000 kg
Lifting/ lowering times	30 / 30 sec		30 / 30 sec		47/40 sec	45 sec
Lifting height	1.965 mm		1.965 mm		2.020 mm	1.890 mm
Lowest pick up point	95 - 140 mm		95 - 140 mm		140 -220 mm	98-140 mm
Diameter of pick-up pads	120 mm		120 mm		120 mm	120 mm
Column height	-		-		-	3.200 mm
Total height	3.902 mm	4.267 mm	3.950 mm 4.300 mm	4.600 mm 4.950 mm	4.600 mm 4.950 mm	3.200 mm 4.200 mm
Switch off height	3.735 mm	4.100 mm	3.756 mm	4.106 mm	4.406 mm 4.756 mm	-
Recommended setup width	Standard: 3.405 mm Wide: 3.558 mm	Standard: 3.405 mm Wide: 3.558 mm	3.599 mm		3.872 mm	2.246 mm
Drive-through width	Standard: 2.228 mm Wide: 2.380 mm	Standard: 2.228 mm Wide: 2.380 mm	2.380 mm		2.776 mm	2.246 mm
Long arms extraction	956 - 1.527 mm		950 - 1.650 mm		900 - 1.900 mm	950 - 1580 mm
Short arms extraction	505 - 1.065 mm		570 - 1.050 mm			460 - 880 mm
Power supply	400-415 VAC 3ph 50 Hz		400-415 VAC 3ph 50 Hz		400-415 VAC 3ph 50 Hz	400-415 VAC 3ph 50 Hz
Drive motor	3 kW		4 kW		4 kW	2 x 1,8 kW
Min. necessary ceiling height	3.955 mm	4.320 mm	4.000 mm	4.650 mm	4.650 mm	3.250 mm

**ADDITIONAL ACCESSORIES ARE AVAILABLE, PLEASE ASK YOUR REPRESENTATIVE**



Energy Unit  
(available for all lifts)



Pick Up Pad Extensions  
75 mm & 150 mm  
(available for all lifts)



Electric Vehicle Footpad Kit



Pick Up Pads For Vans  
and Light Trucks  
(available for HL 4500)

**FIND A DISTRIBUTOR**

**AUSTRIA**  
+43 2641 24524

**FRANCE**  
+33 134 48 58 78

**GERMANY**  
+49 8634 622 0

**ITALY**  
+39 0522 733 411

